

Freestanding Bath Installation Manual



MYLIFE®

**THIS PRODUCT MUST BE INSTALLED
BY A QUALIFIED PLUMBER**

INSTALLATION

1. Remove the Bath from the carton. Ensure the Bath does not come into contact with rough surfaces. Rough surfaces will scratch your Bath. Always ensure that the Bath is placed on cardboard or carpets when laying bath on its side to fit flexible waste connector. Place the Bath in position for installation.

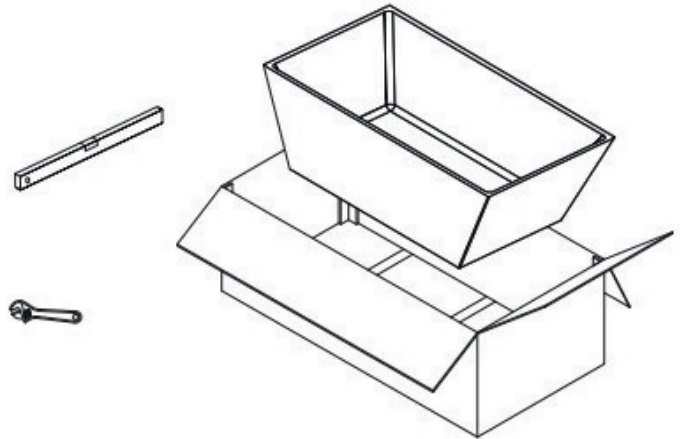

2. Adjust the feet make sure the Bath is level. Only if the Bath is level will all water drain to the waste outlet. Please ensure legs are adjusted in line with the base of bath and ensure leg set is totally load bearing as outer skin is not designed to bear load. Check the bath sits flat.

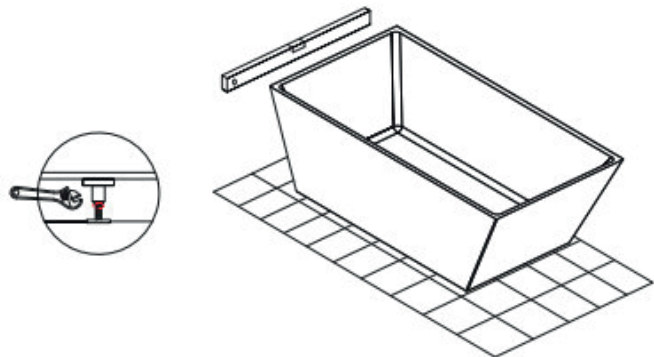

3. Remove the waste from the bath and apply silicone to the rim at the waste position of the bath before reconnecting the waste. Then connect the Bath to the waste outlet.

Allow silicone to set for 24 hours.

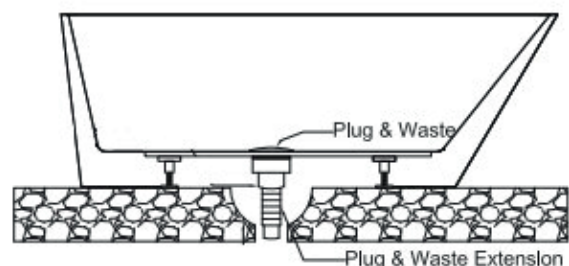

Freestanding Bath Installation Manual



INSTALLATION

4. Finally, you need to do a final test for drainage. Ensure that the thin masking plastic adhered to your bath during manufacture has been removed. Fill the Bath with water and check that ALL the water flows freely to the waste outlet. A small amount of water may pool owing to surface tension.

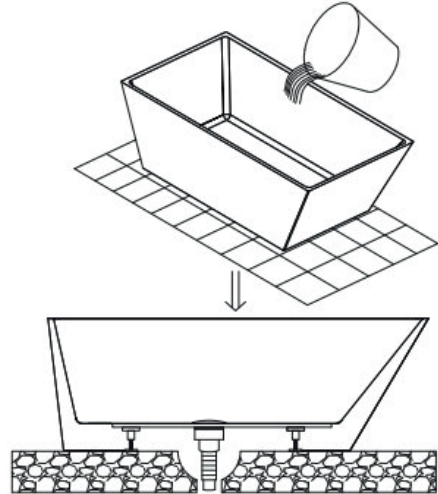

5. Apply a layer of silicon sealant around the bath outline and allow to set 24 hours.



CLEANING AND MAINTENANCE

Cleaning method - Use soft cloth with neutral detergent or soap water.

It is strictly prohibited to use sharp objects or rough cleaning pads in order to avoid damage to the bath surface. Keep away from open flame, high temperature bulbs or cigarette butts etc so as not to burn the bath surface. Avoid the use of the paint, varnish removal agent such as acetone and chloroform organic volume as these may cause the bath surface to soften, dissolve or crack.

Repairs* - If there any slight scratches because of careless use, please use car polish or metal polishing agent on the surface of the area and buff a with microfiber cloth. If the scratch is deep, use 1000# wet sandpaper to remove the scratched area and then apply the above polish application.

****Please note - The above process is for internal area of bath only.***

AFTER SALES & TECHNICAL SUPPORT

Our highly experienced after sales and technical support team are always on hand to help should you require technical advise or a spare part.

T: +44 (0)28 3025 9988 | E: technical@mylifebathrooms.com